

Measuring wheel systems

| | | |
|-------------------------|-------------------------------------|---|
| Performance-Line | Measuring wheel system MWE51 | With spring arm, contact force max. 32.5 N |
|-------------------------|-------------------------------------|---|



With incremental or absolute encoder with clamping flange \varnothing 58 mm.

Measuring wheel systems from Kübler are the ideal solution for reliable speed, position and distance measurement in applications with linear movements. These are recorded rotationally via the measuring wheel with attached encoder directly on the surface of the material to be measured and converted into linear data.

The MWE51 measuring wheel system impresses with its versatile installation options combined with high ease of use. Depending on the requirements, the preload can be set manually in 6 steps from 5 to 30 N.

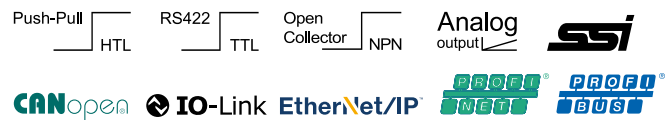

Features

- **Flexible mounting options**

The measuring wheel system can be installed vertically, horizontally or overhead. The encoder can be mounted on both sides of the spring arm in 30° steps.

- **Wide range of encoders**

Incremental Sendix encoders with a max. resolution of up to 36,000 pulses/revolution as well as absolute encoders for different communication interfaces such as IO-Link or Profinet for integration in Industry 4.0 concepts.

- **Suitable measuring wheels for all measuring surfaces**

Circumferences 300 mm or 12" – measuring wheel coating available with O-ring or double O-Ring, smooth or corrugated plastic, diamond knurl surface and tufted rubber.

- **Contact force up to max. 32.5 N**

With manually adjustable preload in 6 steps from 5 to 30 N. To compensate for tolerances, the integrated spring ensures a working range of the measuring wheel of ± 10 mm vertical to the measuring surface (at ± 2.5 N in relation to the respectively set preload). For maintenance, the spring can also be manually brought into a stress-free state.

Construction

- | | |
|---------------------|--|
| ❶ Spring arm: | MWE50 |
| ❷ Mounting bracket: | optional |
| ❸ Encoder: | Clamping flange \varnothing 58 mm |
| ❹ Measuring wheel: | Circumference 300 mm or 12" (Circumference 200 mm or 500 mm on request) |

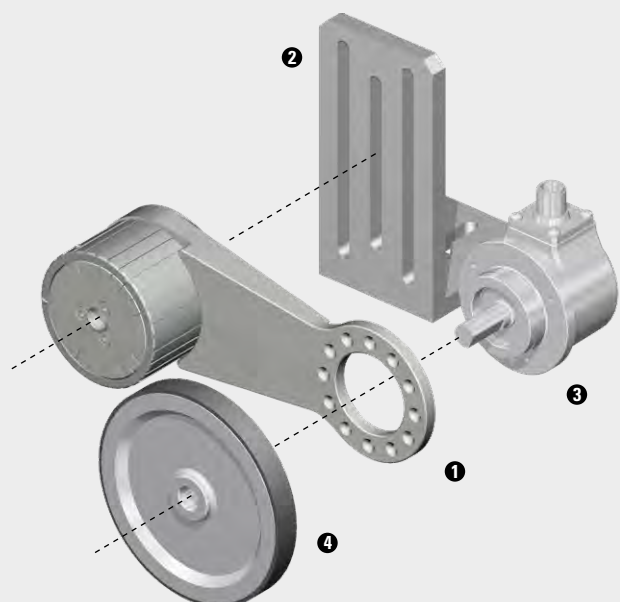

Measuring wheel systems

Performance-Line **Measuring wheel system MWE51** **With spring arm, contact force max. 32.5 N**

Order code with incremental encoder **8.MWE51 . 1 X 1 . XX . XXXX . XXXX**

Type ① ② ③ ④ ⑤

① Mounting bracket
1 = without mounting bracket
2 = with mounting bracket

② Measuring wheel, circumference / coating
31 = 300 mm / diamond knurl (aluminum)
34 = 300 mm / plastic smooth (PU)
36 = 300 mm / tufted rubber (PU)
37 = 300 mm / O-ring (NBR)
38 = 300 mm / double O-ring (NBR)
39 = 300 mm / plastic corrugated (PU)

71 = 12" / diamond knurl (aluminum)
74 = 12" / plastic smooth (PU)
76 = 12" / tufted rubber (PU)
77 = 12" / O-Ring (NBR)
78 = 12" / double O-ring (NBR)
79 = 12" / plastic corrugated (PU)

(Measuring wheels with circumference 200 mm and 500 mm on request)

③ Mounted encoder ¹⁾
50 = KIS50 incremental
05 = 5805 incremental
(other encoders on request)

④ Output circuit / supply voltage encoder
see data sheet encoder

⑤ Type of connection
see data sheet encoder

⑥ Pulse rate
see data sheet encoder

Order code with absolute encoder **8.MWE51 . 1 X 1 . XX . XXXX . XXXX**

Type ① ② ③ ④ ⑤ ⑥ ⑦ ⑧

① Mounting bracket
1 = without mounting bracket
2 = with mounting bracket

② Measuring wheel, circumference / coating
31 = 300 mm / diamond knurl (aluminum)
34 = 300 mm / plastic smooth (PU)
36 = 300 mm / tufted rubber (PU)
37 = 300 mm / O-ring (NBR)
38 = 300 mm / double O-ring (NBR)
39 = 300 mm / plastic corrugated (PU)

71 = 12" / diamond knurl (aluminum)
74 = 12" / plastic smooth (PU)
76 = 12" / tufted rubber (PU)
77 = 12" / O-Ring (NBR)
78 = 12" / double O-ring (NBR)
79 = 12" / plastic corrugated (PU)

(Measuring wheels with circumference 200 mm and 500 mm on request)

③ Mounted encoder ¹⁾
M1 = M5861
M3 = M5863
M8 = M5868
M8 = M5868
F8 = F5868
F8 = F5868
68 = 5868

(other encoders on request)

④ Output circuit / supply voltage encoder
see data sheet encoder

⑤ Type of connection
see data sheet encoder





⑥ + ⑦ + ⑧ Interface specifications
see data sheet encoder

Calculation of the linear resolution

| | Measuring step (mm/pulse) | Resolution (pulses/mm) |
|--|---|---|
| Calculation | $\frac{\text{mm}}{\text{ppr}} = \frac{\text{Measuring wheel circumference}}{\text{Pulse number encoder}}$ | $\frac{\text{ppr}}{\text{mm}} = \frac{\text{Pulse number encoder}}{\text{Measuring wheel circumference}}$ |
| Example Measuring wheel circumference = 300 mm Pulse number encoder = 3000 ppr | $\frac{300 \text{ mm}}{3000 \text{ ppr}} = 0.1 \text{ mm / puls}$ | $\frac{3000 \text{ ppr}}{300 \text{ mm}} = 10 \text{ pulses / mm}$ |

1) Clamping flange 58 mm / shaft ø 10 mm - only relevant for ordering an encoder as a single component.

Measuring wheel systems

| Performance-Line | | Measuring wheel system MWE51 | With spring arm, contact force max. 32.5 N |
|---|--|---|--|
| Single components | | | Order no. |
| Spring arm MWE50 | | combinable with Kübler encoders: clamping flange ø 58 mm incremental: Sendix Base KIS50, 5805 absolute: Sendix F58xx, M58xx, 58xx | 8.MWE50.121.00.0000.0000 |
|  | | | |
| Measuring wheels | | Option ② circumference / coating 31 300 mm / diamond knurl (aluminum) 8.0000.3317.0010 34 300 mm / plastic smooth (PU) 8.0000.3347.0010 36 300 mm / tufted rubber (PU) 8.0000.3367.0010 37 300 mm / O-ring (NBR70) 8.0000.3377.0010 38 300 mm / double O-ring (NBR70) 8.0000.3387.0010 39 300 mm / plastic corrugated (PU) 8.0000.3397.0010 71 12" / diamond knurl (aluminum) 8.0000.3717.0010 74 12" / plastic smooth (PU) 8.0000.3747.0010 76 12" / tufted rubber (PU) 8.0000.3767.0010 77 12" / O-ring (NBR70) 8.0000.3777.0010 78 12" / double O-ring (NBR70) 8.0000.3787.0010 79 12" / plastic corrugated (PU) 8.0000.3797.0010 <small>(Measuring wheels with circumference 200 mm and 500 mm on request)</small> | |
|  | | | |
| Evaluation | | | Order no. |
| Preset counter Codix 924 | | Multifunction device: - Tachometer with limit values - Position indicators with limit values - Time preset counter | 6.924.01XX.XXX |
|  | | | |
| Accessories | | | Order no. |
| Mounting bracket | | Material: Aluminium | 8.0000.7000.0072 |
|  | | | |
| O-rings | | For measuring wheels with O-ring: Measuring wheel circumference 300 mm, ② = 37 8.0000.7000.0074 Measuring wheel circumference 12", ② = 77 8.0000.7000.0075 For measuring wheels with double O-ring: Measuring wheel circumference 300 mm, ② = 38 8.0000.7000.0077 Measuring wheel circumference 12", ② = 78 8.0000.7000.0078 | |
|  | | | |

Further accessories can be found at: kuebler.com/accessories
 Cables and connectors can be found at: kuebler.com/connection-technology

Measuring wheel systems

| | | |
|-------------------------|-------------------------------------|---|
| Performance-Line | Measuring wheel system MWE51 | With spring arm, contact force max. 32.5 N |
|-------------------------|-------------------------------------|---|

Technology in detail

Mounting options encoder on spring arm

The encoder is attached to the spring arm with 3 screws.

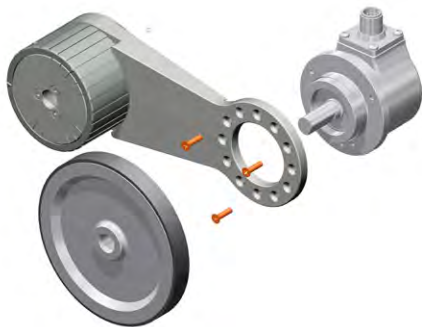

The fastening points are designed in such a way that mounting on both sides of the spring arm is possible.



Mounting left (delivery state)

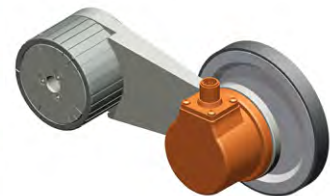

Mounting right

For a flexible outlet direction of the cable or connector, the encoder can additionally be mounted in 30° steps.



0° (delivery state)



30°



60°



90°

Various mounting options

downwards

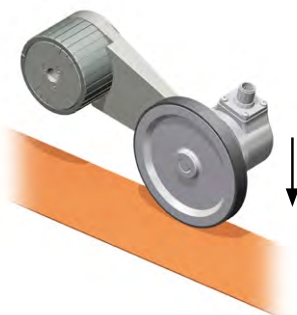

sideways

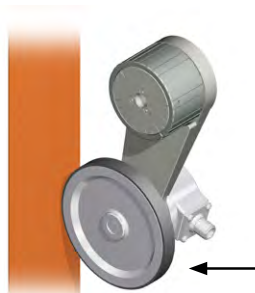

upwards (overhead)

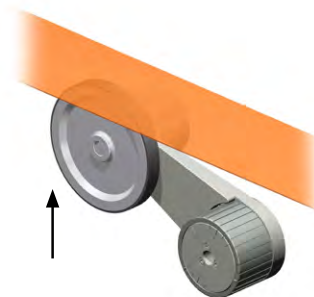

Measuring wheel systems

| | | |
|-------------------------|-------------------------------------|---|
| Performance-Line | Measuring wheel system MWE51 | With spring arm, contact force max. 32.5 N |
|-------------------------|-------------------------------------|---|

Technology in detail

Setting the preload

- Position the measuring wheel system on the measuring surface and fix the corresponding screws in place.
- Pull off the setting wheel to the front.
- Turn to the desired position for the preload (possible in both directions).
- Arrow on the setting wheel points to the corresponding marking.
- Engage the setting wheel.
- Starting from the set preload, this results in a working range of ± 10 mm at ± 2.5 N.

Contact force of the measuring wheel on the

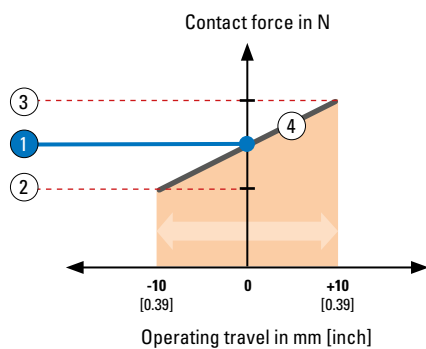

4
Contact force in relation to spring deflection

| 1 | Preload in 6 steps ($\pm 20\%$) | 2 | Contact force min. Operating travel -10 mm | 3 | Contact force max. Operating travel +10 mm |
|---|-----------------------------------|---|--|---|--|
| | 5 N | | 2.5 N | | 7.5 N |
| | 10 N | | 7.5 N | | 10.5 N |
| | 15 N | | 12.5 N | | 17.5 N |
| | 20 N | | 17.5 N | | 22.5 N |
| | 25 N | | 22.5 N | | 27.5 N |
| | 30 N | | 27.5 N | | 32.5 N |

Measuring wheel systems

| | | |
|-------------------------|-------------------------------------|---|
| Performance-Line | Measuring wheel system MWE51 | With spring arm, contact force max. 32.5 N |
|-------------------------|-------------------------------------|---|

Technical data

| Mechanical characteristics spring arm | | |
|---|---------------------------------------|--------------------------|
| Materials | spring spring bracket | spring steel aluminum |
| Weight | 480 g | |
| Contact force, max. | 32.5 N | |
| Praload, adjustable | 5, 10, 15, 20, 25, 30 N | |
| Operating travel, max. | ± 10 mm | |
| Working temperature range | -20 °C ... +70°C [-40 °F ... +176 °F] | |
| Spring operating life | 2.0 Mio. cycles ²⁾ | |
| Shock resistance acc. EN 60068-2-27 | 1000 m/s ² , 6 ms | |
| Vibration resistance acc. EN 60068-2-6 | 100 m/s ² , 55 ... 2000 Hz | |

| Approvals | |
|-------------------------------|---|
| UL compliant acc. to | File no. E224618 |
| CE compliant acc. to | EMV guideline 2014/30/EU RoHS guideline 2011/65/EU |
| UKCA compliant acc. to | EMC Regulations S.I. 2016/1091 RoHS Regulations S.I. 2012/3032 |

Measuring wheel systems

| | | |
|-------------------------|-------------------------------------|---|
| Performance-Line | Measuring wheel system MWE51 | With spring arm, contact force max. 32.5 N |
|-------------------------|-------------------------------------|---|

Dimensions

Dimensions in mm [inch]

Spring arm MWE50 in combination with measuring wheel and encoder KISS50

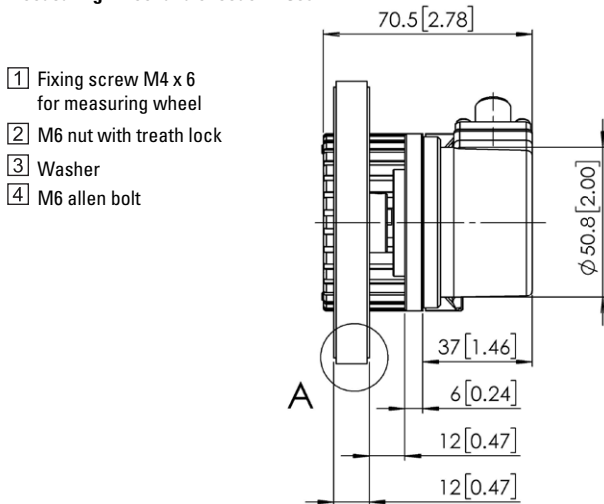

- 1 Fixing screw M4 x 6 for measuring wheel
- 2 M6 nut with treath lock
- 3 Washer
- 4 M6 allen bolt

| Measuring wheel circumference | ø D mm [inch] |
|-------------------------------|---------------|
| 200 mm | 63.7 [2.50] |
| 300 mm | 95.54 [3.76] |
| 500 mm | 159.23 [6.26] |
| 12" | 97.07 [3.82] |

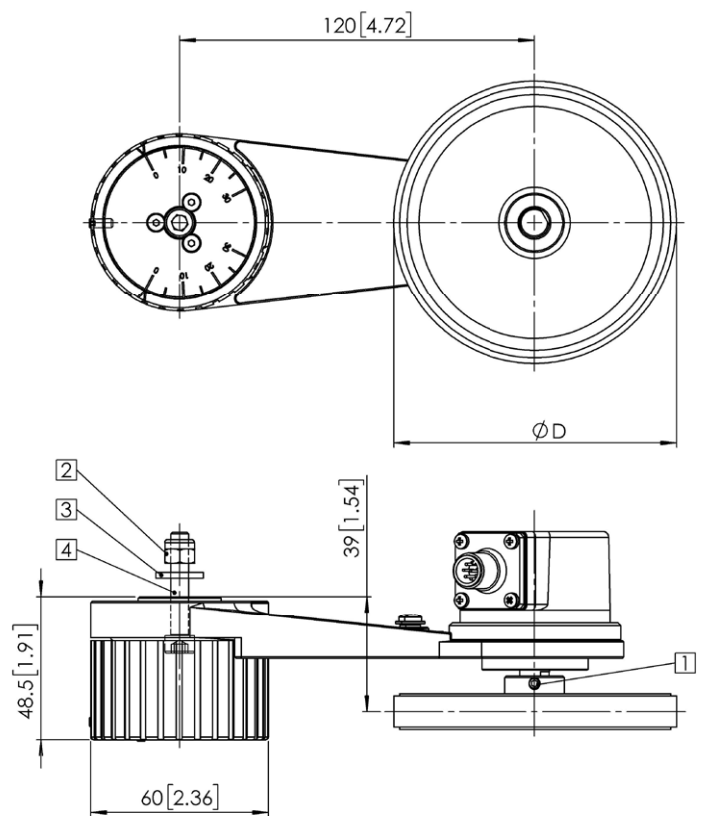

A for measuring wheel with coating:

Diamond knurl (aluminum)

Plastic smooth (PU)

Tufted rubber (PU)

O-ring (NBR)

Double O-ring (NBR)

Plastic corrugated (PU)

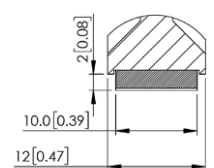
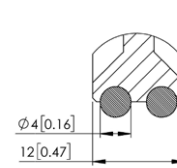
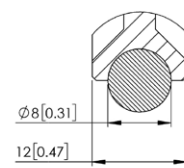
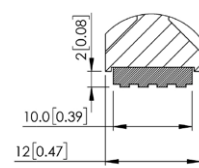
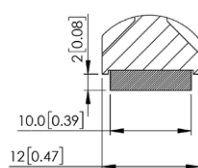
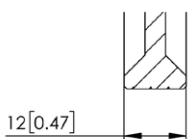

Mounting bracket

