

# Measuring wheel systems

<b>System components</b> <b>Performance-Line</b>	<b>Spring arm MWE60</b>	<b>Contact force max. 40 N</b>
---	-------------------------	--------------------------------



**For encoders with clamping flange ø 58 mm.**

The MWE60 spring arm in combination with an encoder and a measuring wheel as measuring wheel system MWE61 or MWE62 is the ideal solution for reliable speed measurement, position detection and length measurement in applications with linear movements.

These robust measuring wheel systems offer maximum spring deflection at maximum contact force to compensate for tolerances vertical to the transport movement of the material to be measured.

## Features

- **High, variable contact pressure up to 40 N**

During installation, the desired contact pressure can be easily adjusted according to requirements. Depending on the installation situation, the springs allow a maximum Operating travel of 80 mm.

- **Suitable measuring wheels**

Circumferences 300 mm or 12" – measuring wheel coating available with O-ring or double O-Ring, smooth or corrugated plastic, diamond knurl surface and tufted rubber.

- **Flexible mounting options**

The measuring wheel system can be installed vertically, horizontally or overhead. The encoder can be mounted on the spring arm in 120° steps.

<b>Order code</b>	<b>8.MWE60 . 1 21 . 00 . 0000 . 0000</b>
Type	<div style="display: flex; align-items: center;"> <div style="border: 1px solid black; padding: 2px;">1</div> <div style="margin-left: 5px;">21</div> <div style="margin-left: 5px;">00</div> <div style="margin-left: 5px;">0000</div> <div style="margin-left: 5px;">0000</div> </div>

- ❶ **For encoder with clamping flange**
  - 1 = ø 58 mm – Kübler Sendix encoder incremental KIS50, 5000, 5805
  - Kübler Sendix encoder absolute 586x, M586x, F586x

- Scope of delivery*
- Spring arm
  - 3 screws for encoder mounting

# Measuring wheel systems

<b>System components</b> <b>Performance-Line</b>	<b>Spring arm MWE60</b>	<b>Contact force max. 40 N</b>
---	-------------------------	--------------------------------

**Technology in detail** (operating principle of the MWE60 spring arm in the MWE61 or MWE62 measuring wheel system)

## Mounting

The encoder is attached to the spring arm with 3 screws.



For a flexible outlet direction of the cable or connector, the encoder can additionally be mounted in 120° steps.



0° (delivery state)



120°

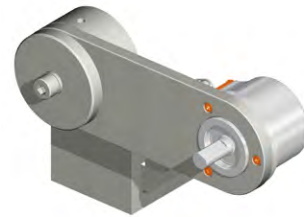

240°

## Various mounting options

downwards

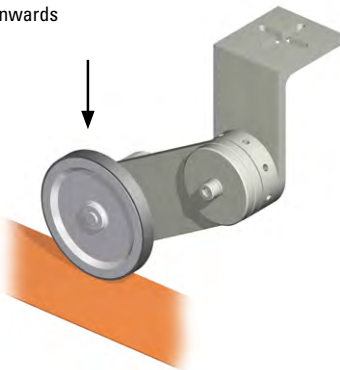

sideways

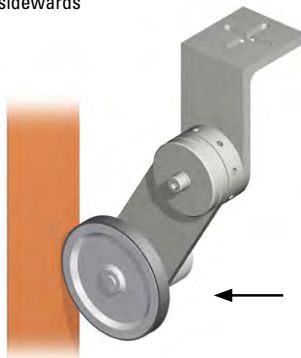

upwards (overhead)

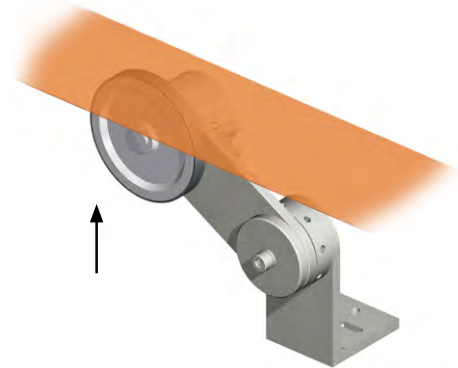

# Measuring wheel systems

<b>System components</b>	<b>Spring arm MWE60</b>	<b>Contact force max. 40 N</b>
<b>Performance-Line</b>		

**Technology in detail** (operating principle of the MWE60 spring arm in the MWE61 or MWE62 measuring wheel system)

### Setting the preload

1. Mount the measuring wheel system on the application and release screw.
2. Turn the adjustment ring with a thin allen key or screwdriver until the desired preload is reached.
3. As a guide: Internal detent points in 45° steps correspond to approx. 20 N. Hold the position of the adjustment ring and tighten the screw again.

### Installation example

Preload ca. 20 N

**Preload**

**Contact force max.**

**Contact force min.**

③ Spring deflection limitation

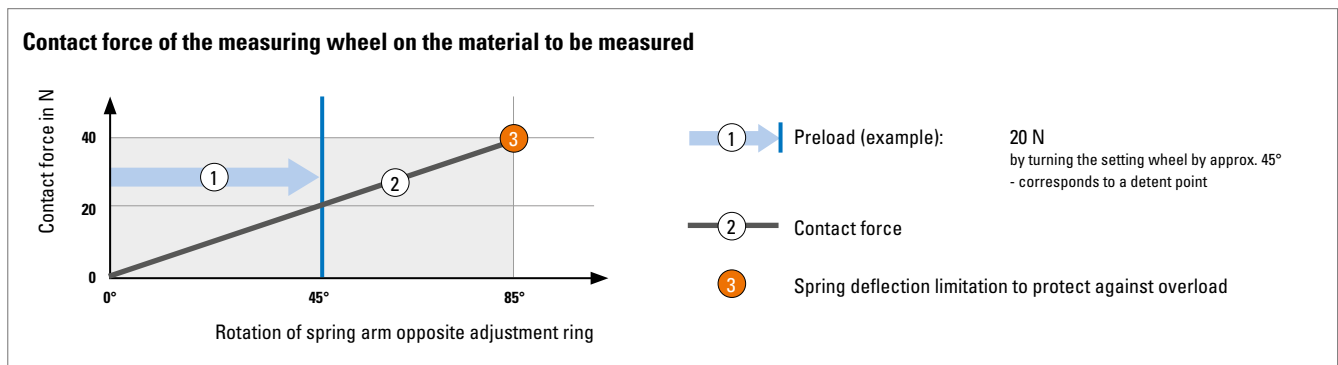

# Measuring wheel systems

<b>System components</b>	<b>Spring arm MWE60</b>	<b>Contact force max. 40 N</b>
<b>Performance-Line</b>		

## Technical data

Mechanical characteristics spring arm		
<b>Materials</b>	spring spring bracket	spring steel aluminum
<b>Weight</b>	670 g	
<b>Contact force, max.</b>	40 N	
<b>Operating travel, max.</b>	80 mm	
<b>Working temperature range</b>	-20 °C ... +70°C [-40 °F ... +176 °F]	
<b>Shock resistance</b> acc. EN 60068-2-27	1000 m/s <sup>2</sup> , 6 ms	
<b>Vibration resistance</b> acc. EN 60068-2-6	100 m/s <sup>2</sup> , 55 ... 2000 Hz	

Approvals	
<b>UL compliant</b> acc. to	File no. E224618
<b>CE compliant</b> acc. to	RoHS guideline 2011/65/EU
<b>UKCA compliant</b> acc. to	RoHS Regulations S.I. 2012/3032

### Dimensions

Dimensions in mm [inch]

- 1 Screw M8x60 DIN912 (SW6)

